

1. Remove 4X ¼-20 Button-Head Screws along with the 3X ¼-20 Nylok Nuts highlighted below using 5/32" Allen key and 7/16 wrench.
2. Remove 1X Index Handle completely.
3. Flip the Mount Bracket by 180 degrees as shown below.
4. Tighten the 4X Button-Head Screws and the 3 Nylok Nuts using same tools used in step 1.
5. Tighten the Index Handle.

If the dock is wider than 10.375", modify the mount as shown

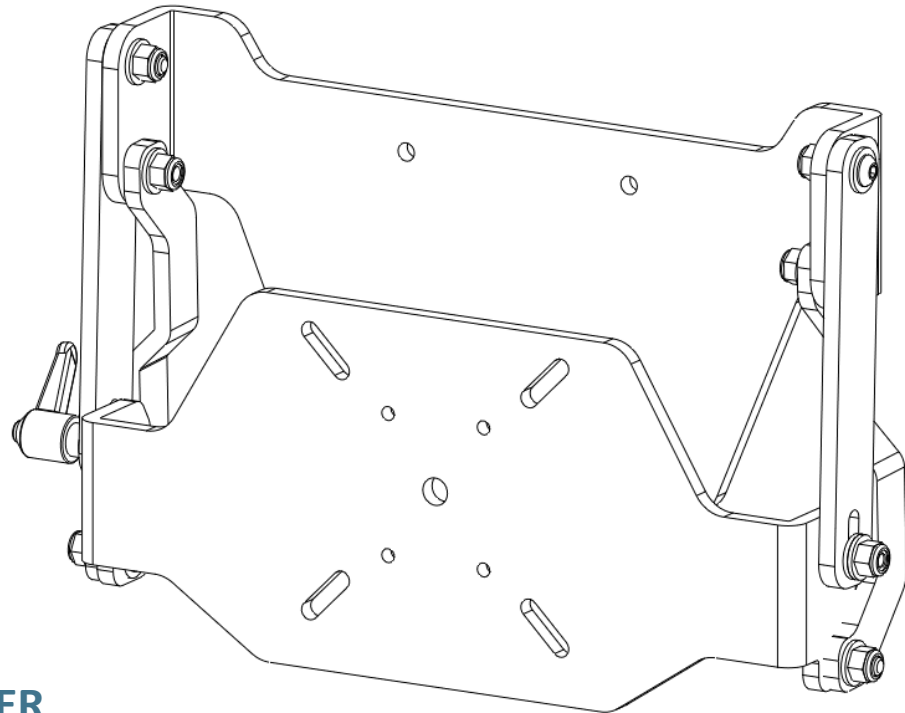

AFTER

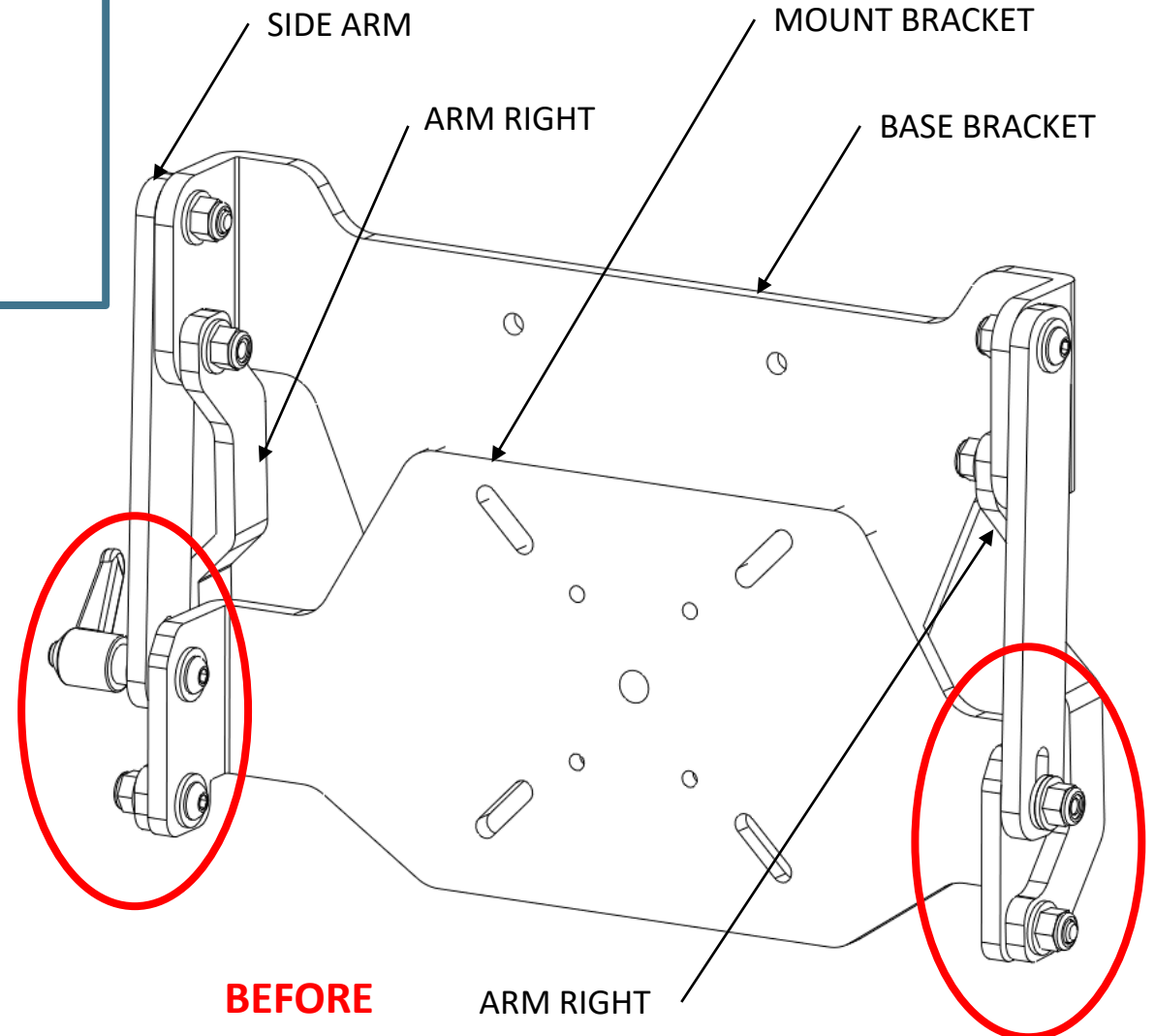

BEFORE

ARM RIGHT