



# INSTALLATION INSTRUCTIONS

## Product

7170-0849-00 - STEEL STANDARD BAR  
7170-0849-01 - STEEL LIGHT BAR  
7170-0849-02 - ALUMINUM STANDARD BAR  
7170-0849-03 - ALUMINUM LIGHT BAR

## Revision

A

## Form

INST-1006

Description: 2021+ CHEVROLET TAHOE PPV/SSV PUSH BUMPER

Printing Spec: PS-005

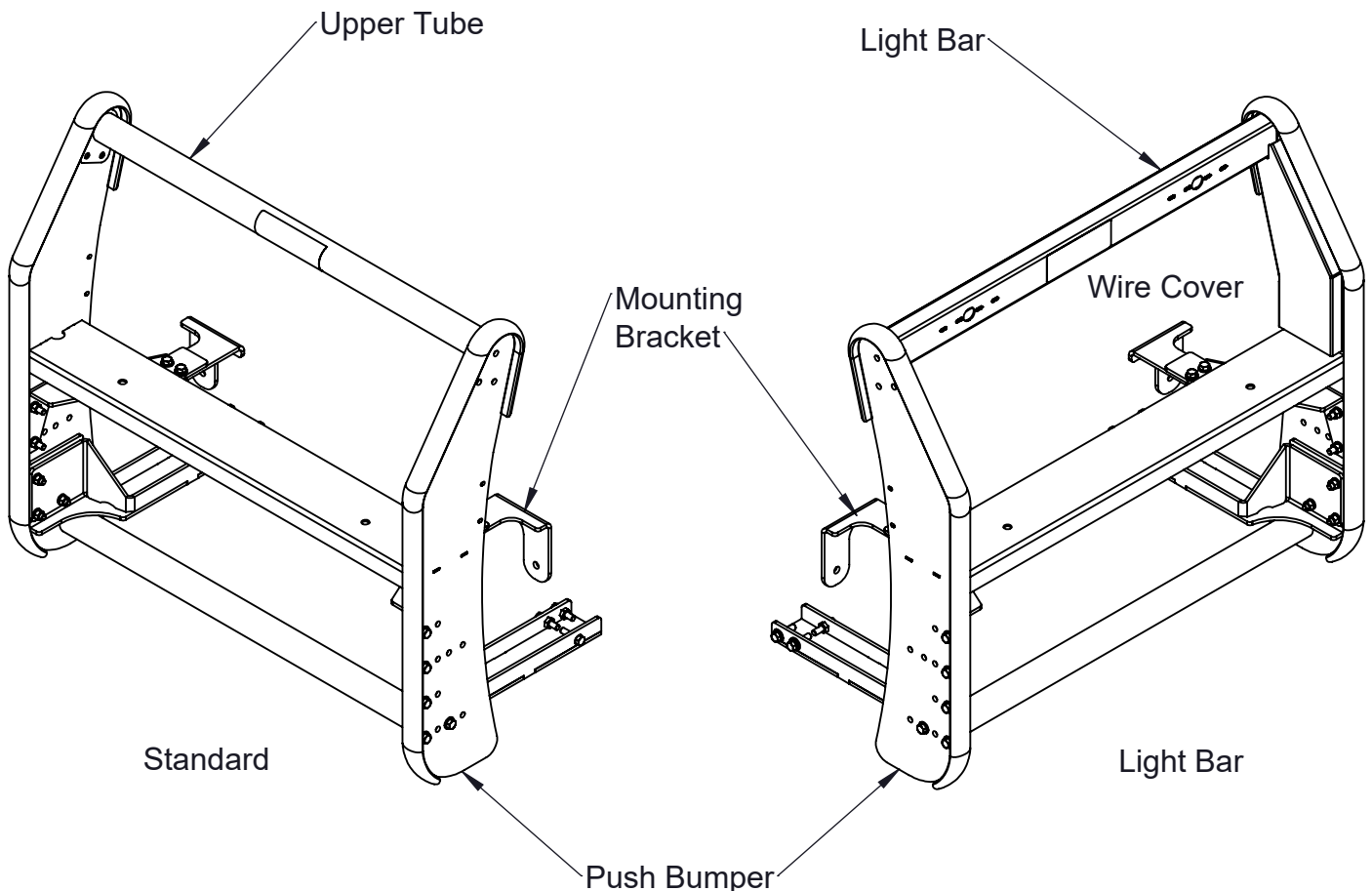

### Product Mounting Disclaimer

Gamber-Johnson is not liable under any theory of contract or tort law for any loss, damage, personal injury, special, incidental or consequential damages for personal injury or other damage of any nature arising directly or indirectly as a result of the improper installation or use of its products in vehicle or any other application. In order to safely install and use Gamber-Johnson products full consideration of vehicle occupants, vehicle systems (i.e., the location of fuel lines, brake lines, electrical, drive train or other systems), air-bags and other safety equipment is required. Gamber-Johnson specifically disclaims any responsibility for the improper use or installation of its products not consistent with original vehicle manufactures specifications and recommendations, Gamber-Johnson product instruction sheets, or workmanship standards as endorsed through the Gamber-Johnson Certified Installer Program.

© Copyright 2020 Gamber-Johnson, LLC

If you need assistance or have questions, call Gamber-Johnson at 1-800-456-6868

ITEM	QTY	PARTNO	DESCRIPTION
1	1	7160-1372	UPPER BAR - STEEL
	1	7160-1521	UPPER BAR - ALUMINUM

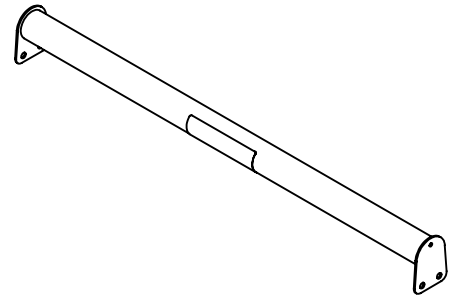

ITEM	QTY	PARTNO	DESCRIPTION
1	1	7160-1373	LIGHT BAR - STEEL
	1	7160-1523	LIGHT BAR - ALUMINUM

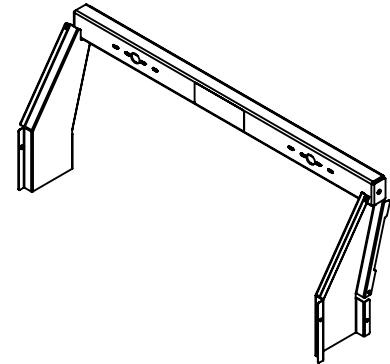

ITEM	QTY	PARTNO	DESCRIPTION
1	1	7160-1365	BUMPER - STEEL
	1	7160-1519	BUMPER - ALUMINUM

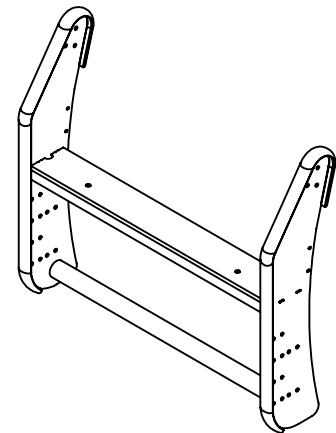

ITEM	QTY	PartNo	DESCRIPTION
1	1	19667	BRACKET - LOWER PASSENGER SIDE
2	1	19668	BRACKET - LOWER DRIVER SIDE
3	1	19671	BRACKET - OUTER UPPER PASSENGER SIDE
4	1	19672	BRACKET - INNER UPPER PASSENGER SIDE
5	1	19676	BRACKET - OUTER DRIVER SIDE
6	1	19675	BRACKET - INNER DRIVER SIDE
8	1	7120-0972	HARDWARE BAG - 2021+ TAHOE PPV/SSV PUSH BUMPER

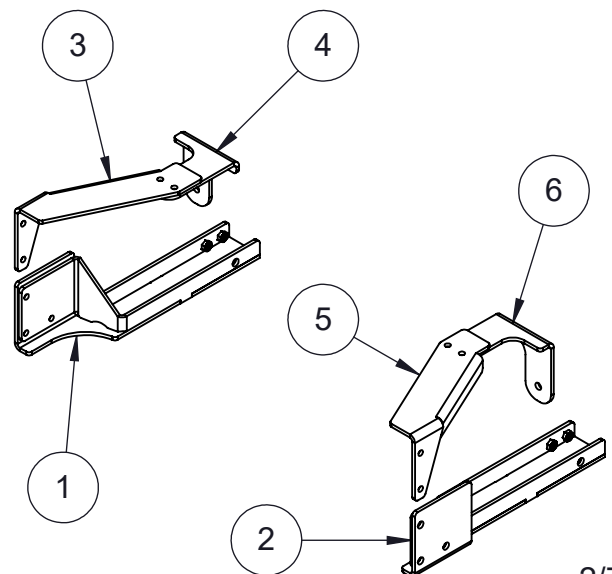

Install:

1. To install brackets, first remove (2) screw holding hood latch with T15 bit, then use a trim tool to remove pop-up clips holding upper panel.



Fig. 1

2. Remove the (6)10mm bolts holding on bottom fender (blue arrow) and (8) torx screw with T15 bit.

**\*If vehicle is equipped with tow hooks, remove the tow hooks as well with 18mm sockets.**



Fig. 2

3. In side front wheel well, remove (3) screw with T15 bit and pull back the wheel well liner to get access to (3) 10mm bolts holding the fender. Repeat on driver side

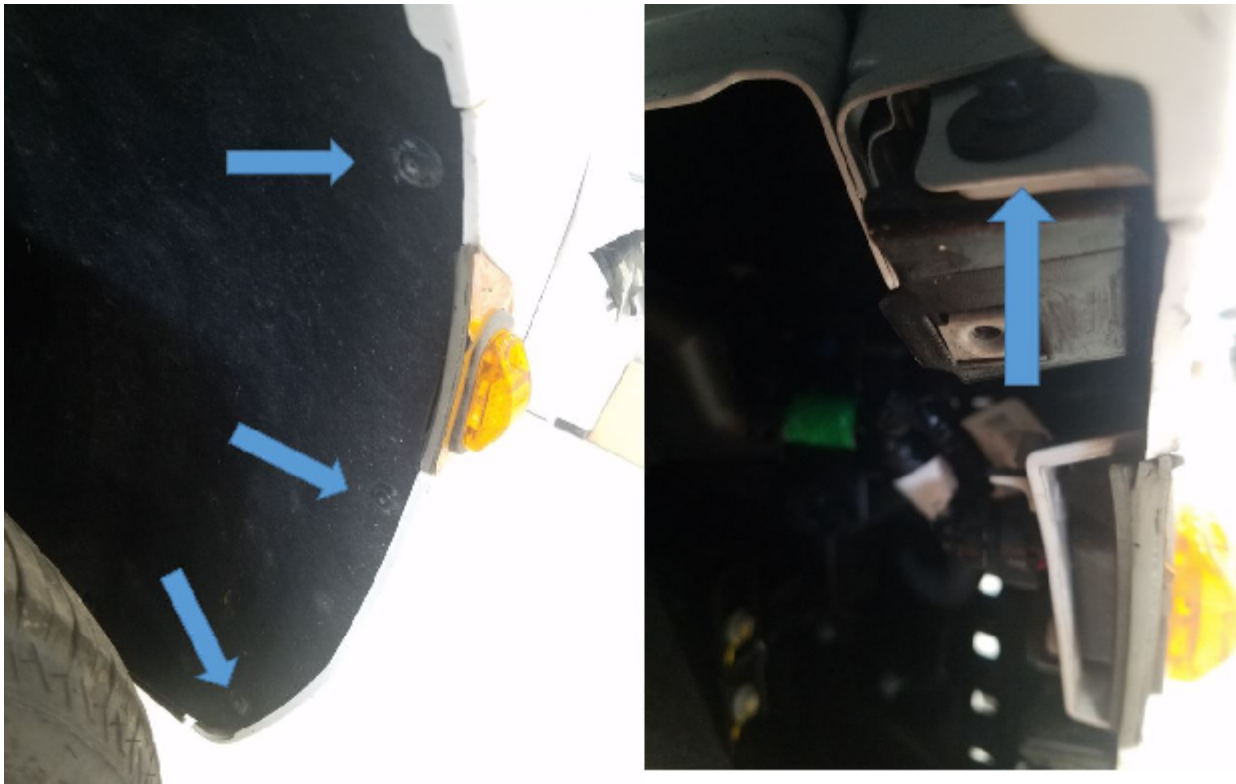

Fig. 3

4. BEFORE REMOVEING GRILL AND FACIA MAKE SURE ALL WIRE HARENESS AND CONNECTORS ARE DISCONNECTED.

Grill and facia can be removed by pulling foward on it.

5. With front facia removed, remove lower air guide by first remove pop-out clips with a trim tool and pulling foward (Fig. 4), then cut out opening for upper bracket as shown in Fig. 5. on both side of OEM air guide.

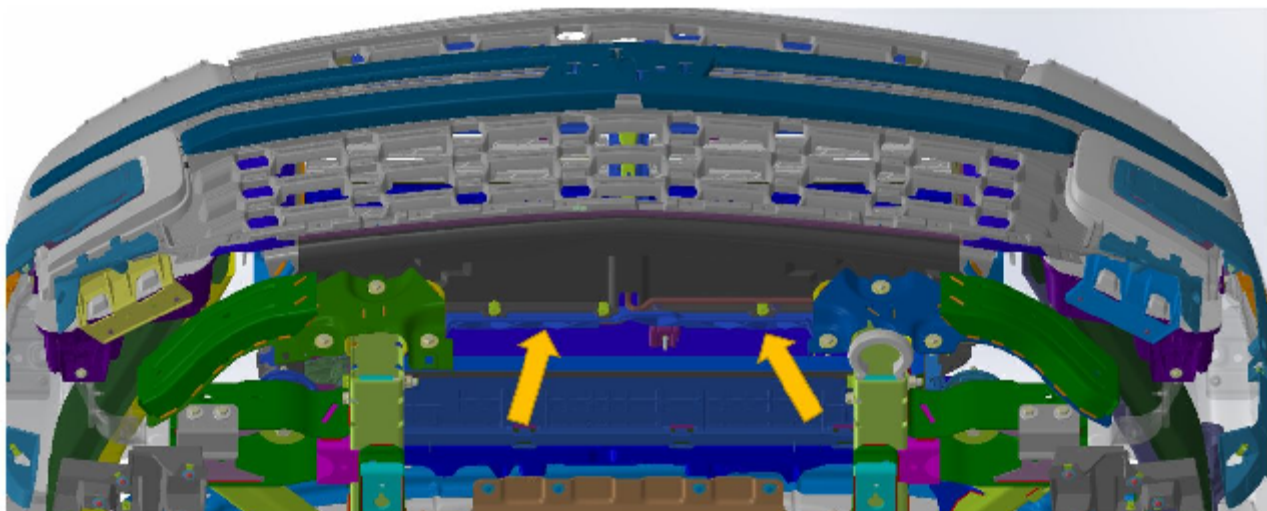

Fig. 4

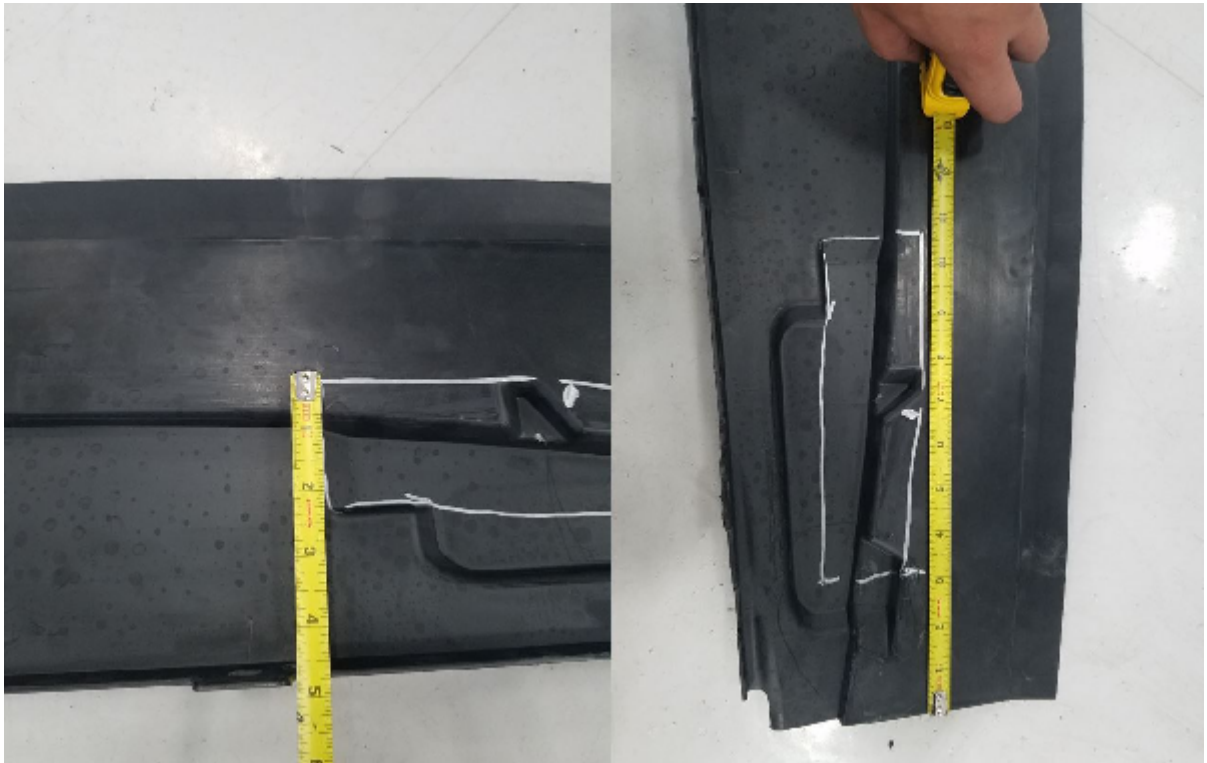

Fig. 5

6. Upper grill trimming, on inside grill need to trim two outer grill clips (blue arrow, Fig. 6), \*grill clips may require to trim top half (long flange) to match the length of the lower flange (trim blue arrow side)

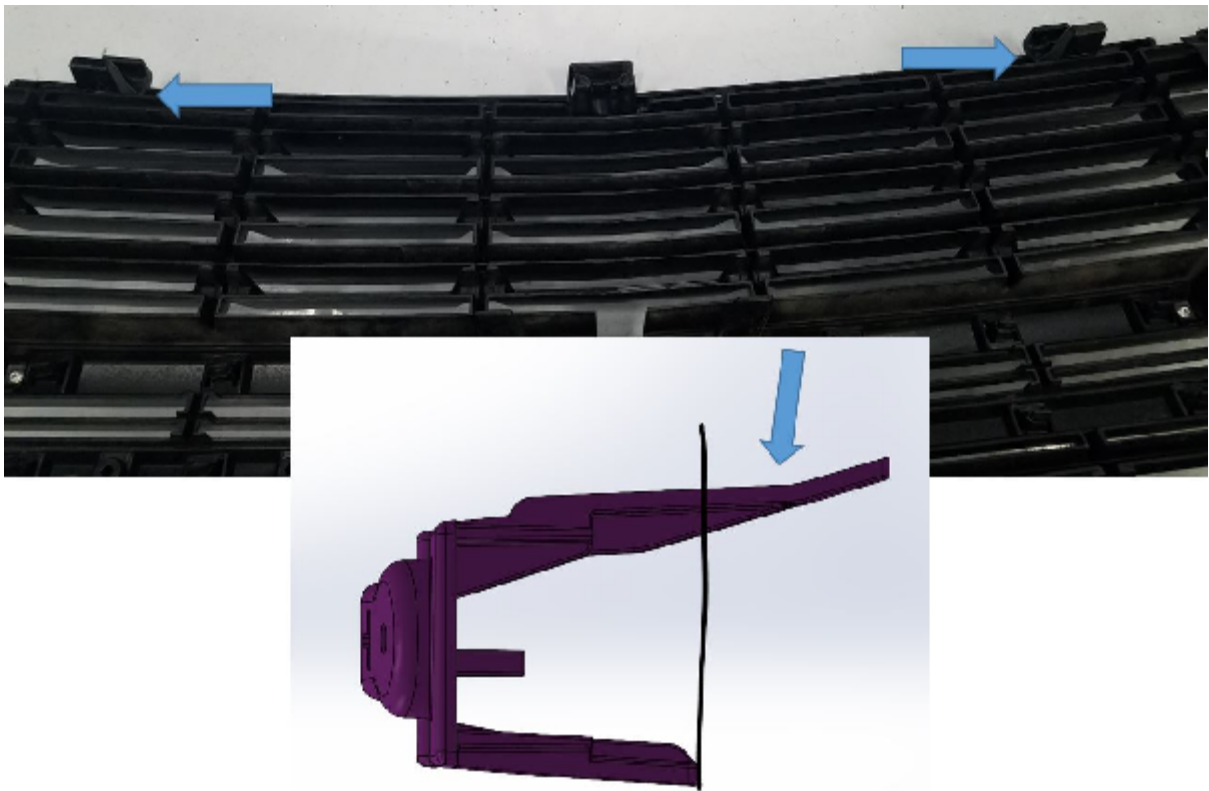

Fig. 6

7. Remove top bolt on both side of the vehicle with 15mm socket (blue arrow), then install GJ inner upper bracket (Item #4 & #6) with OEM bolt and tighten to OEM spec  
**\*when tighten make the bracket is level with respect to ground**

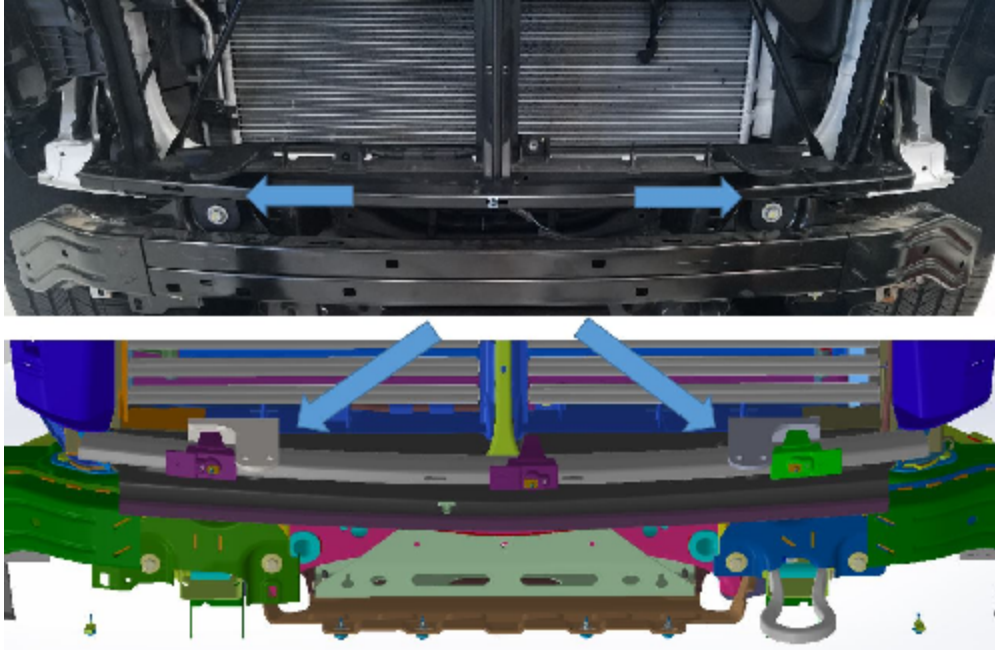

Fig. 7

8. Reinstall OEM upper grill and front fascia. Connect any harness that was disconnect.

9. With OEM parts reinstalled, bolt on the outer upper bracket (item #3 & #5) to the Inner bracket (see Fig 10 for hardware). with the lower bracket (Item #1 & #2) slide in the OEM tow hook location bolt on with provided GJ hardware.

**\*if desired the tow hook trim on the fascia can be trimmed for a better fit.**

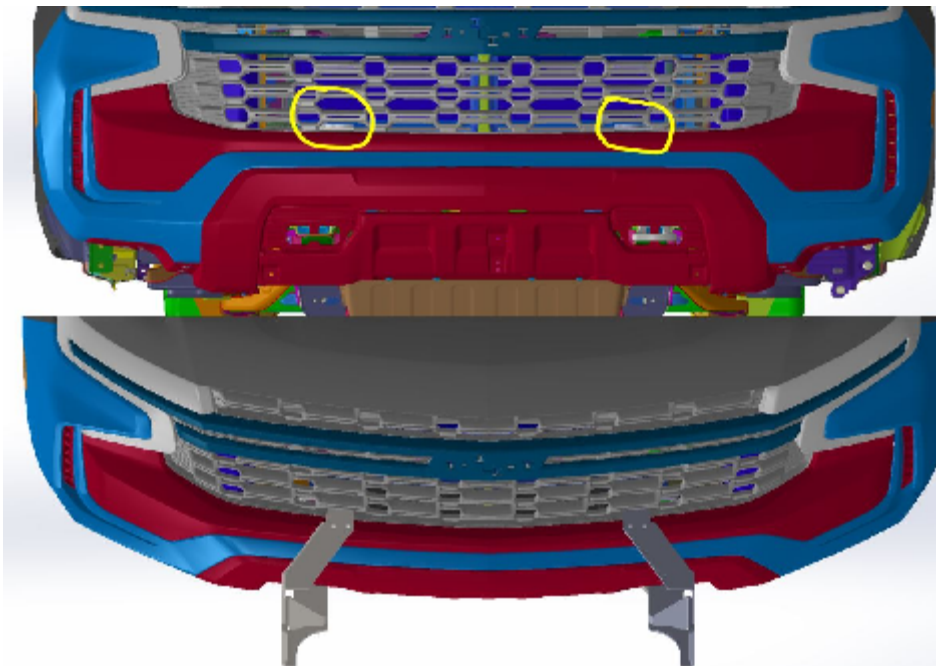

Fig. 8

10. With brackets installed on vehicle, attach GJ push bumper to brackets with provided G8 3/8 hardware. GJ push bumper offers 2 position mounting, if customer desire the push bumper closer or far away from OEM bumper (see Fig. 10).

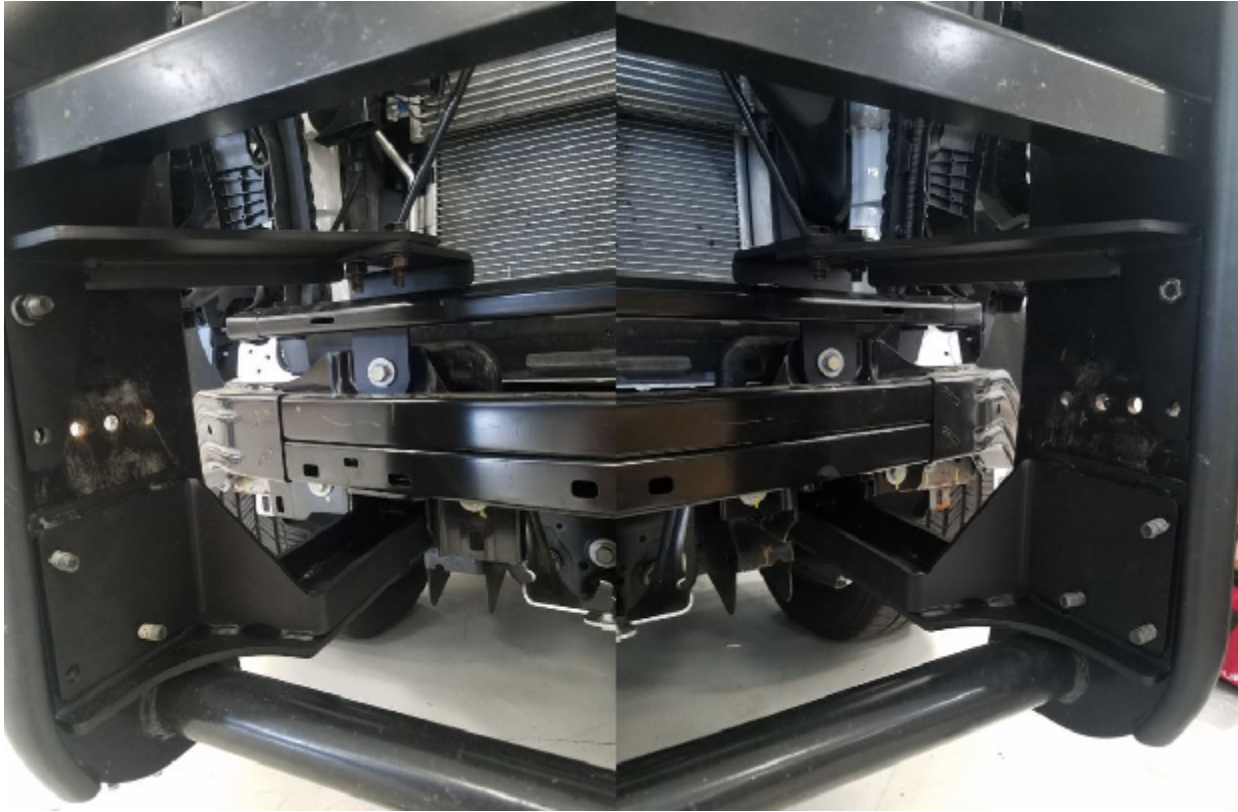

Fig. 9 \*OEM Facia removed for clarity

Position Locator  
 Push: Marked "P"  
 Standard: Marked "S"

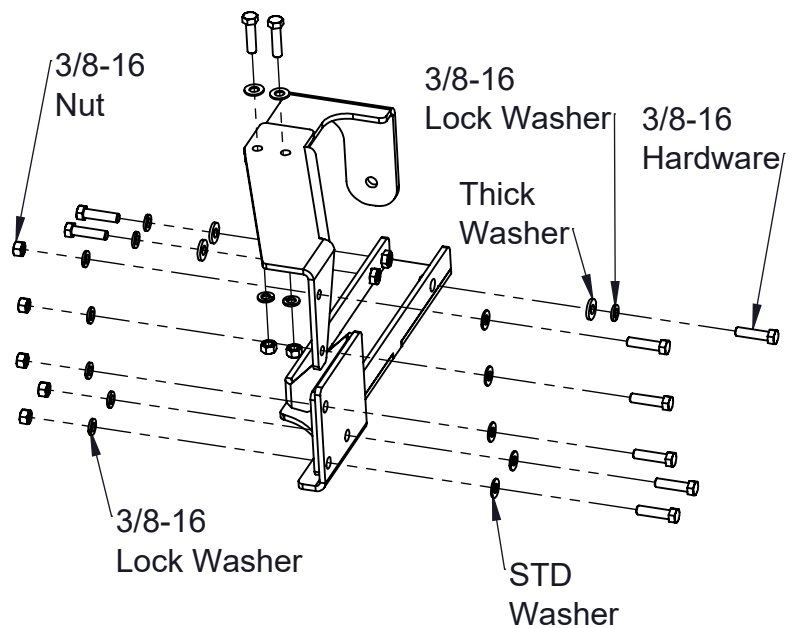
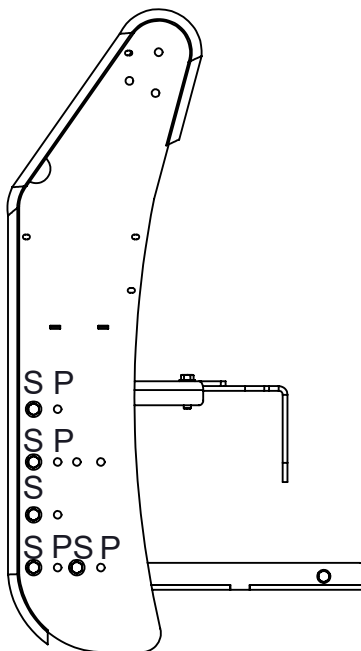

Fig. 10