



# 2020+ Ford Police Interceptor Utility Cencom/Path finder/ Vtec light and siren only Dashmount

## User Guide

Description	Part Number
2020+ Ford Police Interceptor Utility Cencom/Path finder/ Vtec light and siren only Dashmount	AS4.C235.301 AS4.C235.302 AS4.C235.303

[www.precisionmounts.com](http://www.precisionmounts.com)

call us at 1-888-869-7652 | [info@precisionmounts.com](mailto:info@precisionmounts.com)

# DESCRIPTION OF PARTS

2020+ Ford Police Interceptor Radio dash mount plate

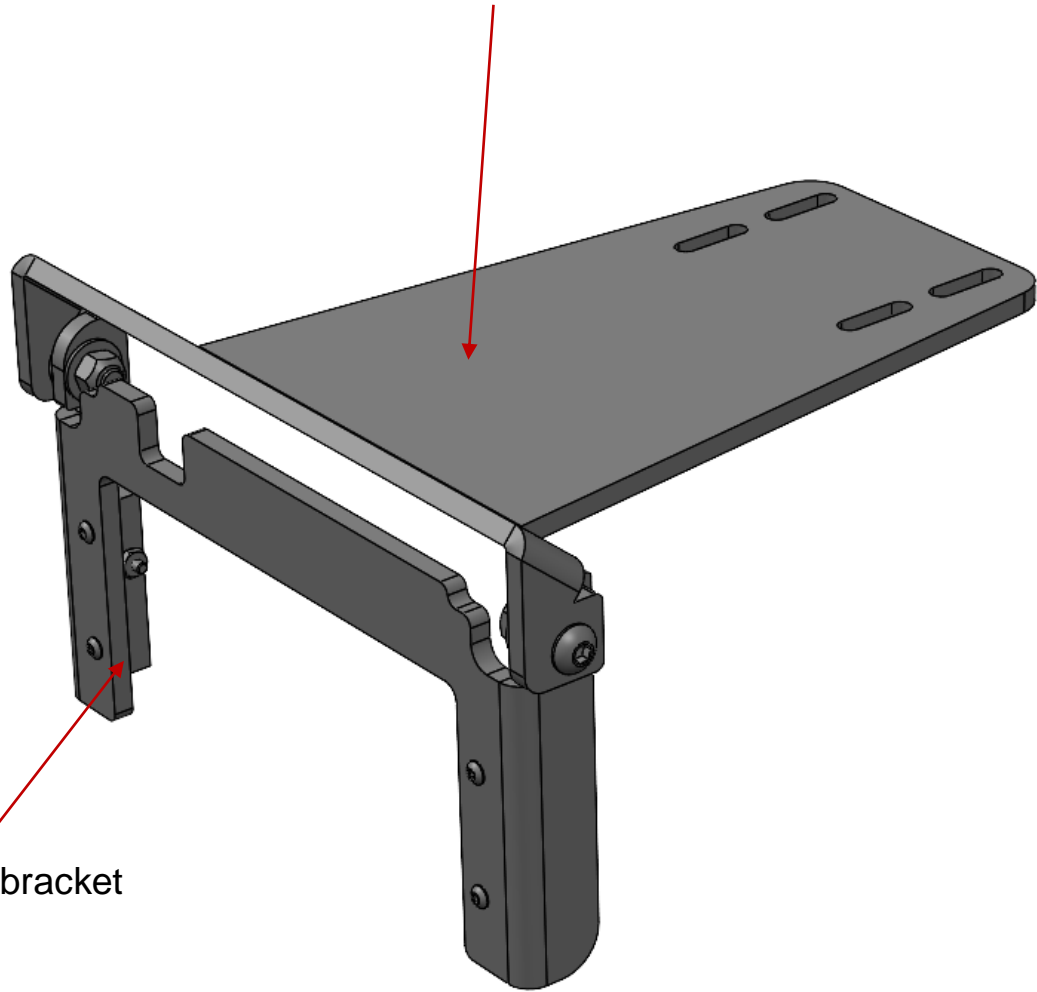

Cencom head bracket

- **Dashmount radio plate**: This plate attaches to vehicle dash over the trim panel of vehicle dash.
- **Cencom head bracket**: This bracket attaches to the dash plate and accommodates the Cencom signal device

# INSTALLATION INSTRUCTIONS

AS4.C235.301,AS4.C235.302,AS4.C235.303

## 2020+ Ford Police Interceptor Utility Cencom/Path finder/ Vtec light and siren only Dashmount

### Tools required:

- Allen key set suitable for #1/4-20 and M5 heads.
- 1/4-20 Hex socket head wrench

### Fastener Torque Specifications

- 1/4-20 Hex Heads - 49-66 ft-lbs
- M5 Socket button head - 8-15 ft-lbs

**Note:** the pictures used/shown here are only for CENCOM HEAD

**Step 1:** Remove the dash tray OEM mounting holes hardware by using M5 socket head allen key as shown in Pic 1 below.



Pic 1

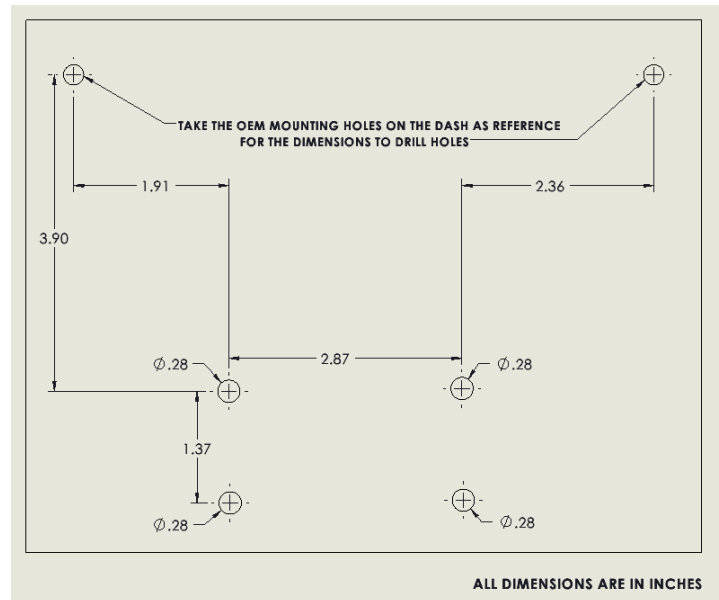

Pic 2

**Step 2:** Use the dimensions shown in Pic 2 to Drill 4x #1/4-20 clearance holes on the dash tray and plate beneath the tray as per the location of 4 holes

OEM mounting holes

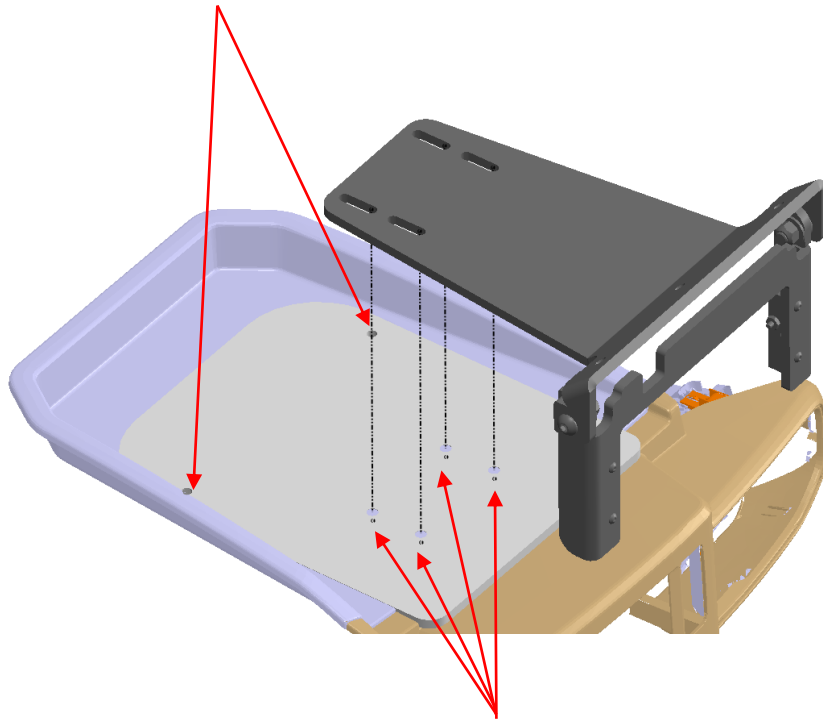

4x ¼-20 clearance holes to be drilled

Pic 3

Ensure to reflect the drill holes **through the plate – underneath the dashmount tray** shown in Pic 4. Pic 4 does not show the holes on the plate, the holes have to be drilled by the installer as per the dimensions outlined in after proper alignment as shown in Pic 4.

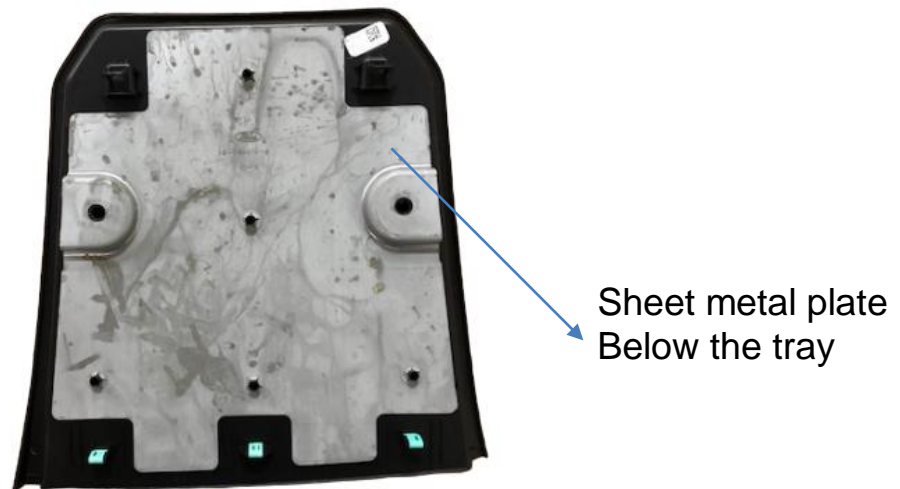

Pic 4

**Step 3:** Use 4x ¼-20 Hex head bolt with nuts supplied to assemble the dashmount unit to the OEM dash tray as shown in picture below.

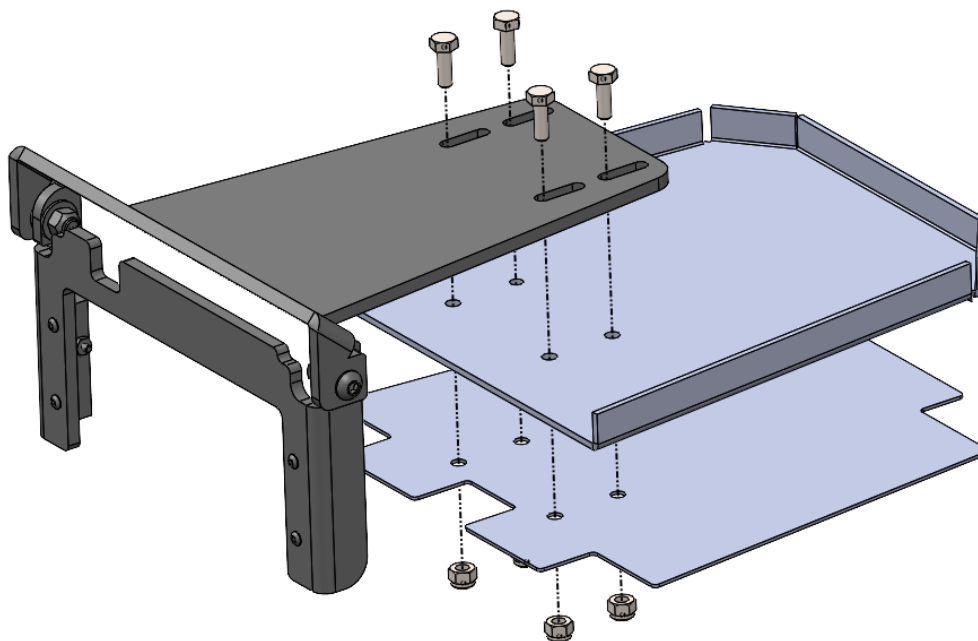

Pic 5

**Step 4:** Assemble the unit- dash mount with OEM dash tray on to the vehicle dash by using the M5 screws – which were removed in Step 1, the final installation looks as shown below.



Pic 6